

Third CEPII-IDB CONFERENCE

**THE NEW REGIONALISM: PROGRESS, SETBACKS
AND CHALLENGES**

Washington, DC, February 2006

The Rise of Regionalism

Antoni Estevadeordal

**Integration and Regional Programs Department
Inter-American Development Bank**

Outline

- I. The Rise of Regionalism
- II. Understanding a Complex Trading System: What should be the Debate?
- III. What do we know about the economic effects of RTAs?
- IV. Looking Beyond Economics: RTAs as building blocks for Regional Cooperation

I

The Rise of Regionalism
in Today's World Trading System

Current INTRA-regional + INTER-regional (2003-2005)

+ APEC (1989)

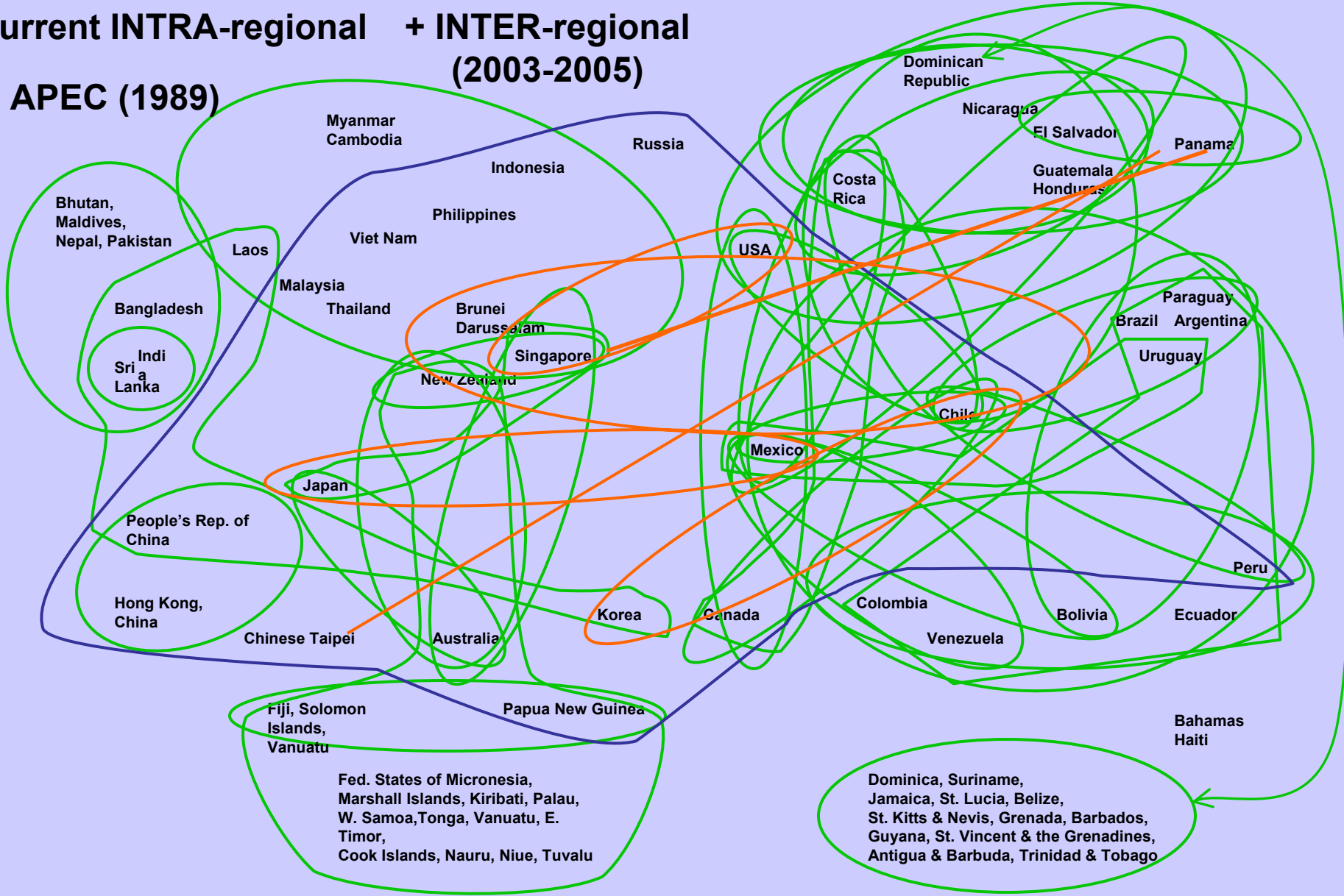

ASIA

AMERICAS

UNDER NEGOTIATION

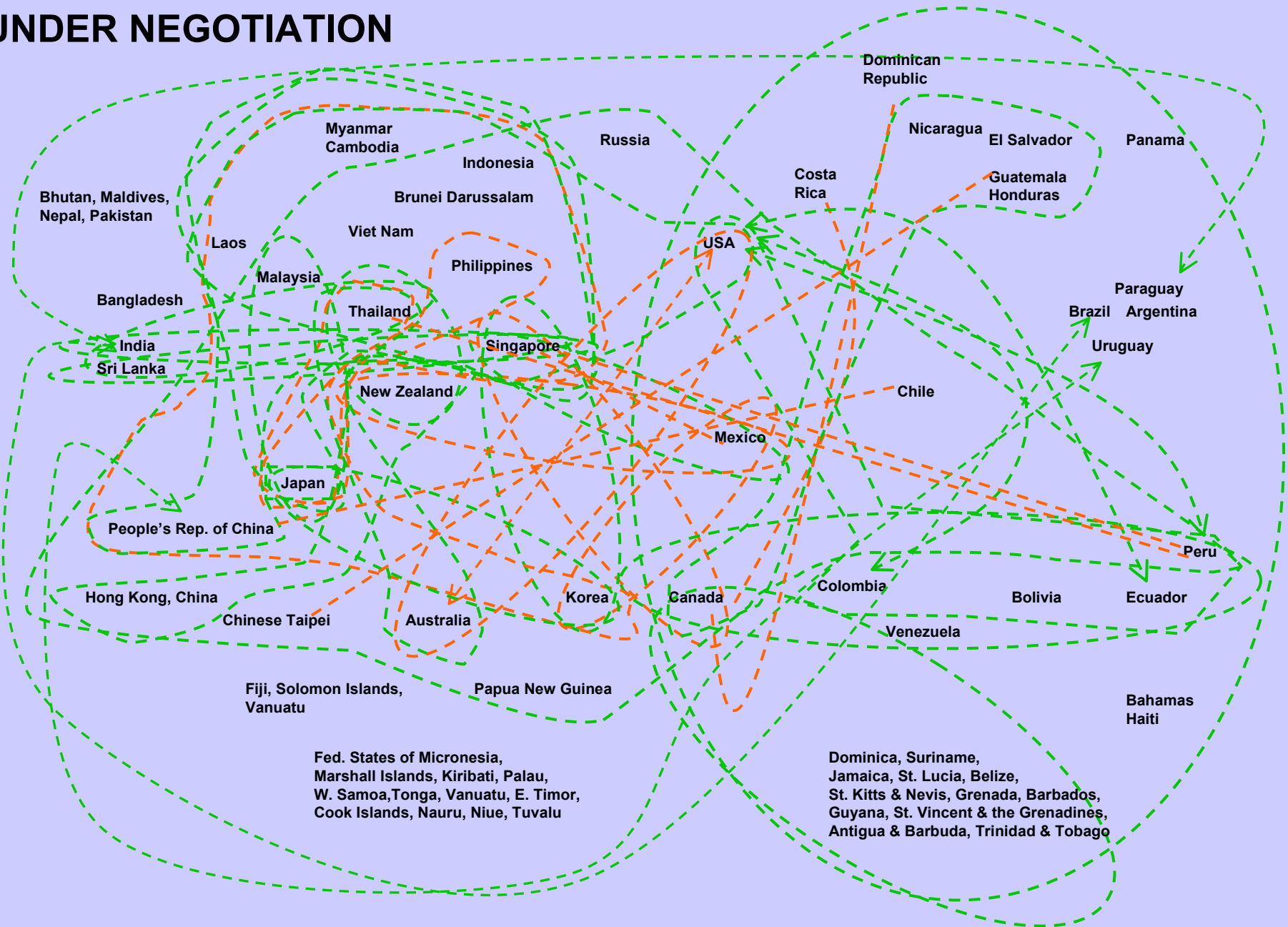

ASIA

AMERICAS

II

Understanding a Complex Trading System. What should be the Debate?

- RTAs and WTO
- Regional Integration in Europe:
 - RTAs and European Enlargement
- Regional Integration in the Americas:
 - RTAs and the FTAA
- Regional Integration in Asia-Pacific:
 - RTAs and APEC

WTO and RTAs

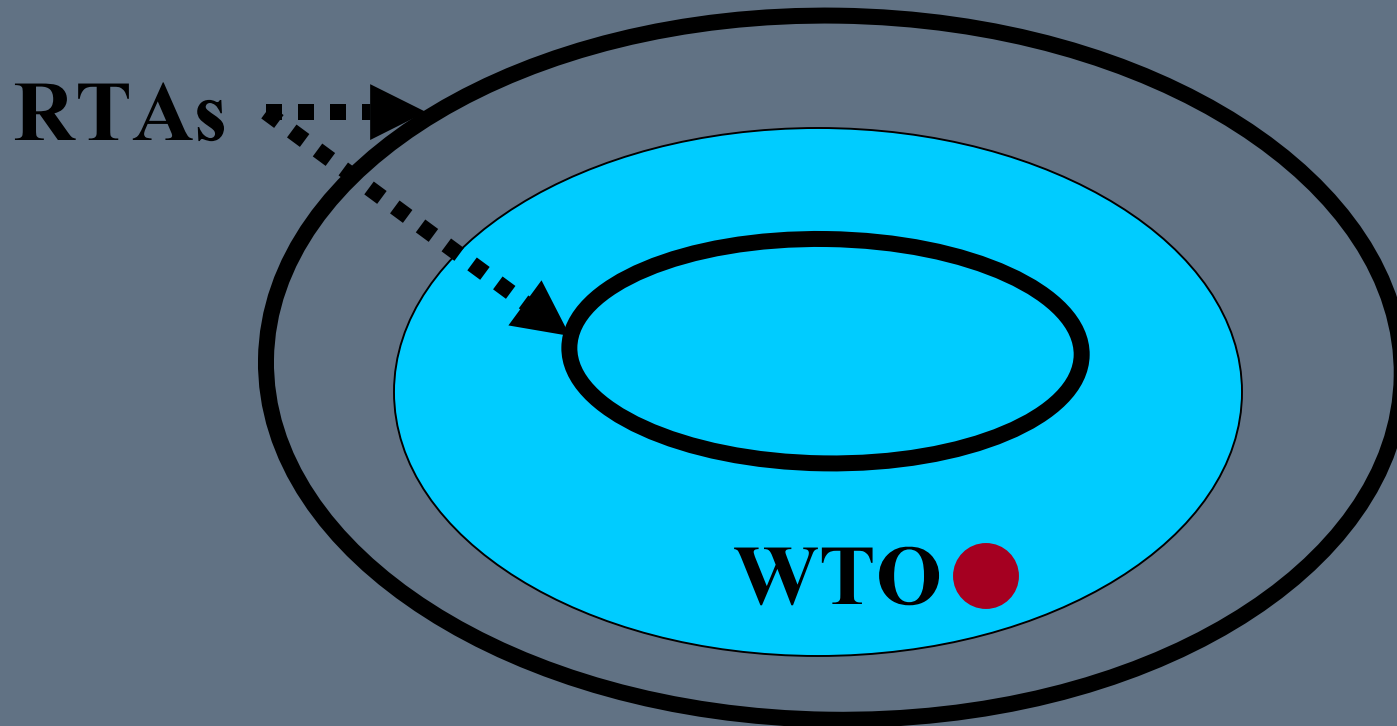

WTO as the “Center of Gravity” of the World trading System: New Regional Rules? ●

Regional Integration in Europe

FTAs in European Expansion

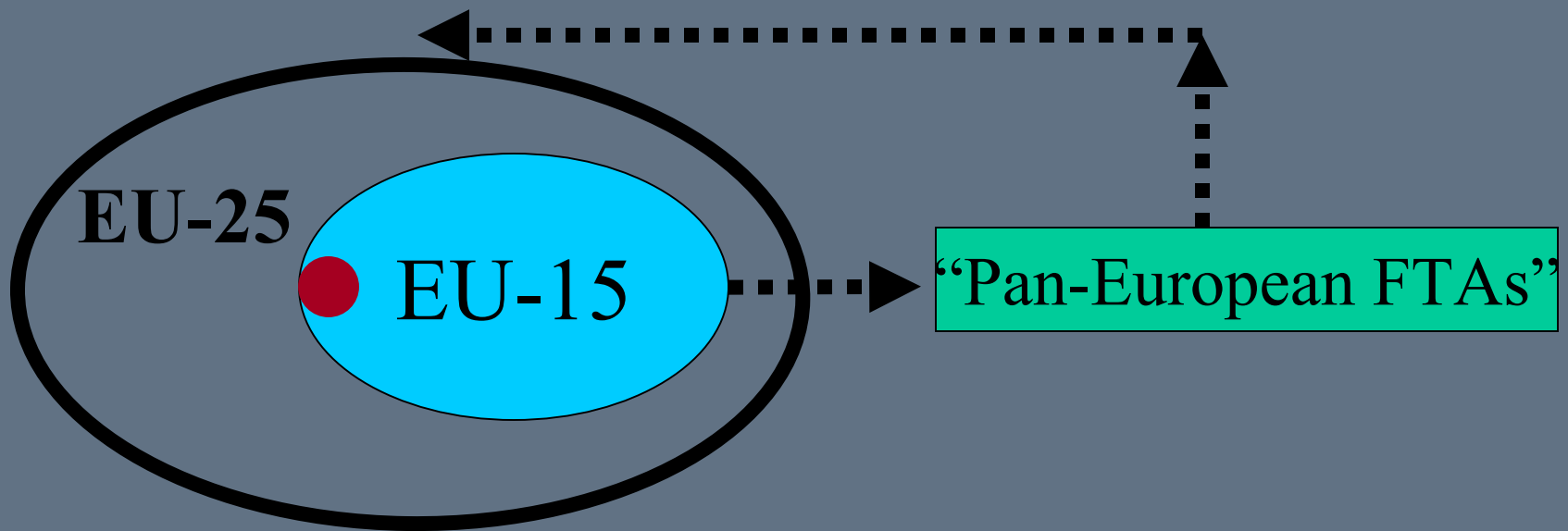

EU-15 “center of gravity” of an
“Pan-European System of FTAs”



Regional Integration in the Americas

RTAs and The FTAA

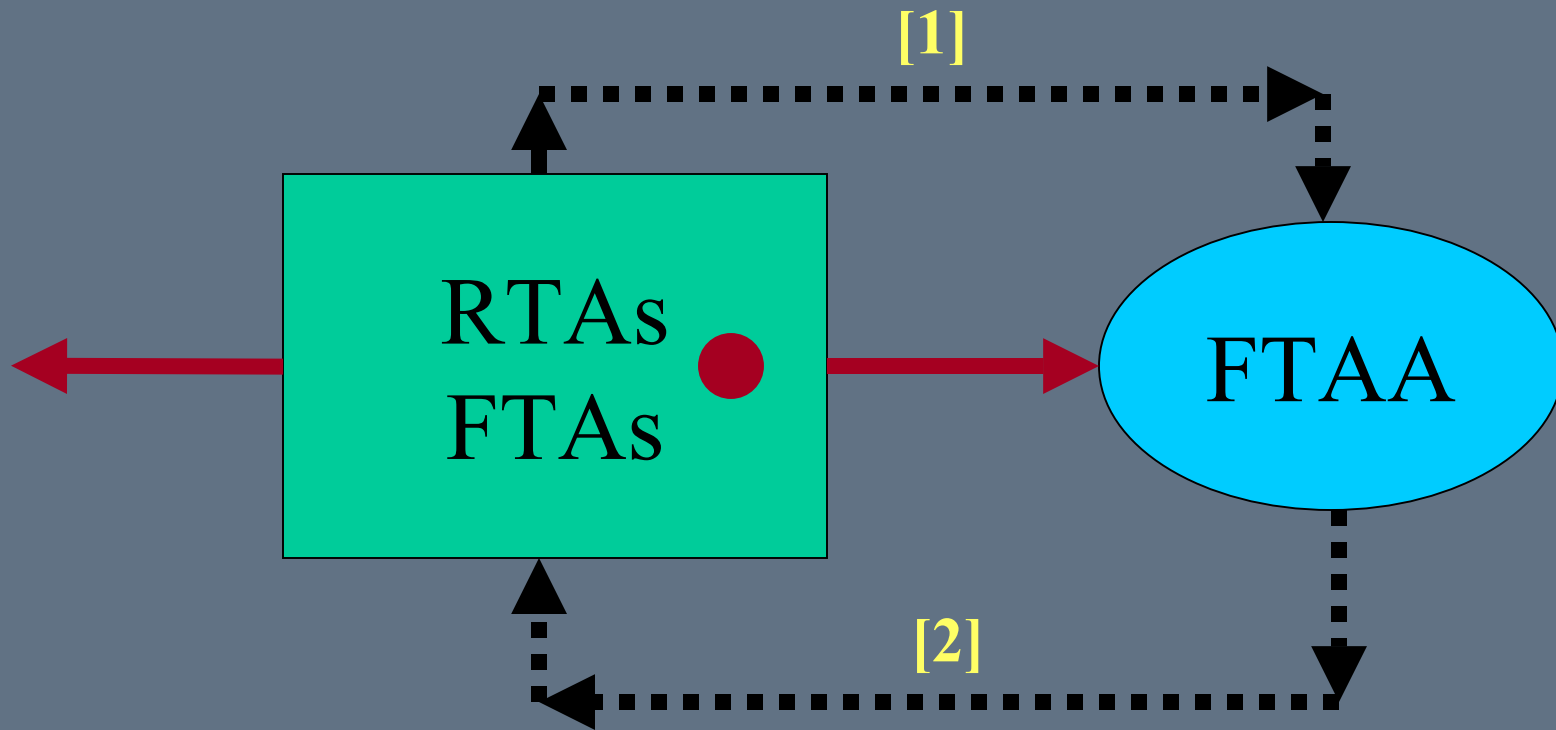

The FTAA is no longer the “Center of Gravity”
in The Americas ●

Regional Integration in Asia-Pacific

RTAs and APEC

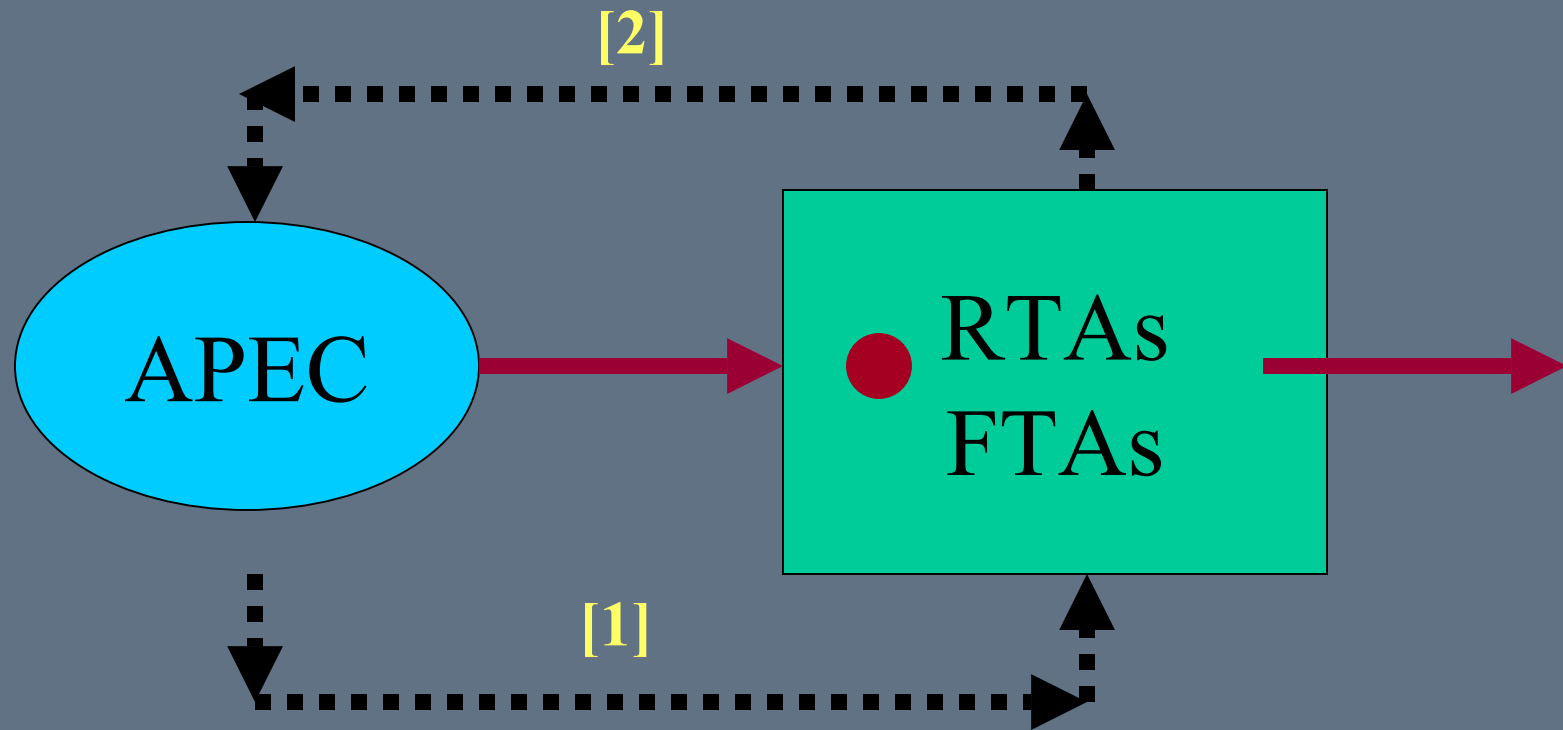

APEC is no longer the “Center of Gravity”
in Asia-Pacific ●

III

What do we know about the economic effects of RTAs?

- *Preferential tariff liberalization*...has promoted unilateral trade liberalization
- ...but *Rules of Origin* create problems....

Preferential TARIFF liberalization

Simultaneous Preferential and MFN Liberalization in Latin America

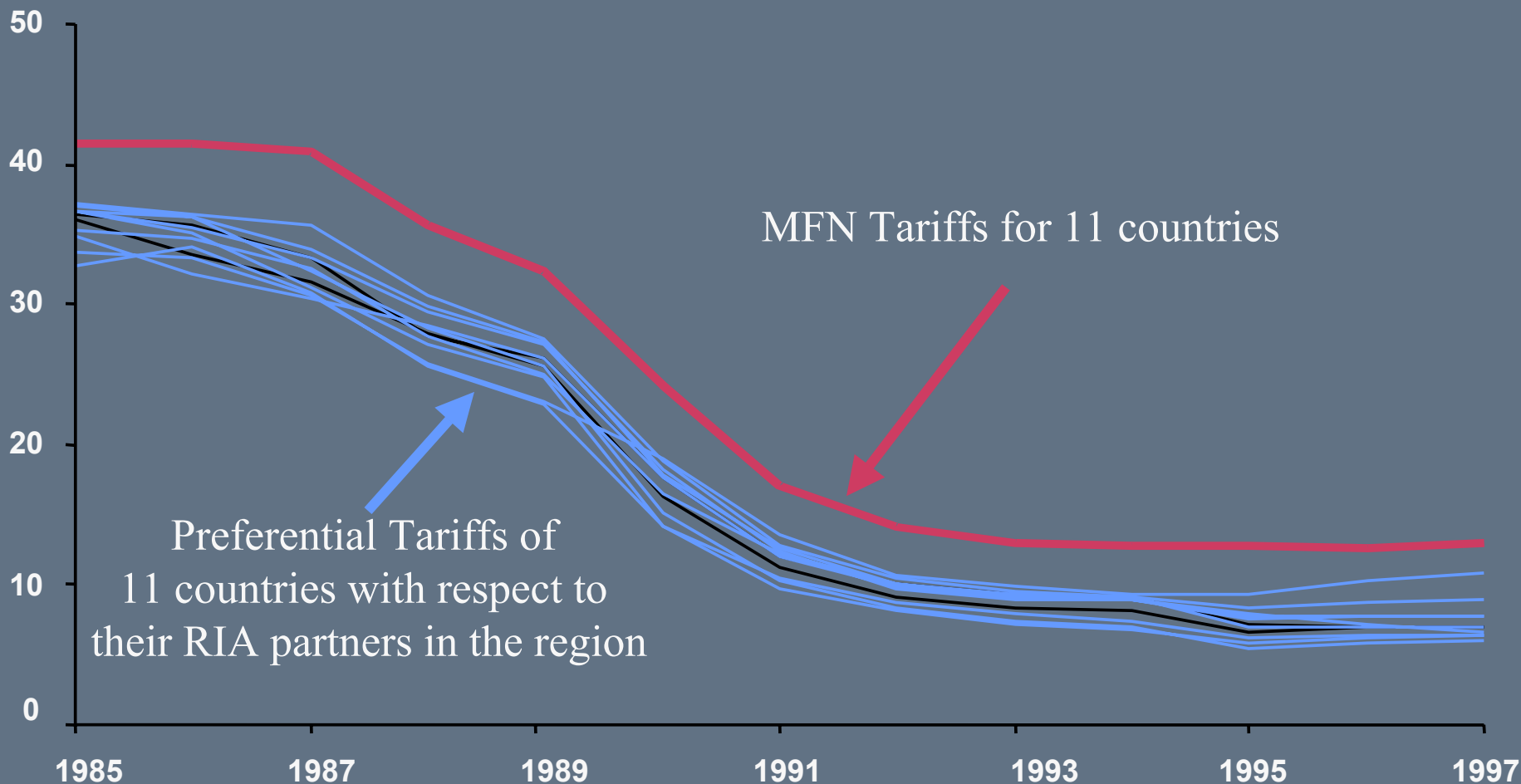

...but Rules of Origin

- Preferential RoO define the share of inputs that have to be used or production processes that have to be performed within an RTA in order for the good to be considered originating
- The MAIN justification for preferential RoO is to ensure that non-members do not obtain access to PTA preferences (to avoid trade deflection)

.....but Rules of Origin

- Growing theoretical analysis: RoO used as protectionist devices and potential for distorting trade, investment, and production patterns
- Growing empirical evidence: RoO have an economic impact on
 - Trade, investment and production patterns
 - Customs and Firms' administrative costs
 - Utilization of trade preferences

Trade Effects of FTAs with Rules of Origin

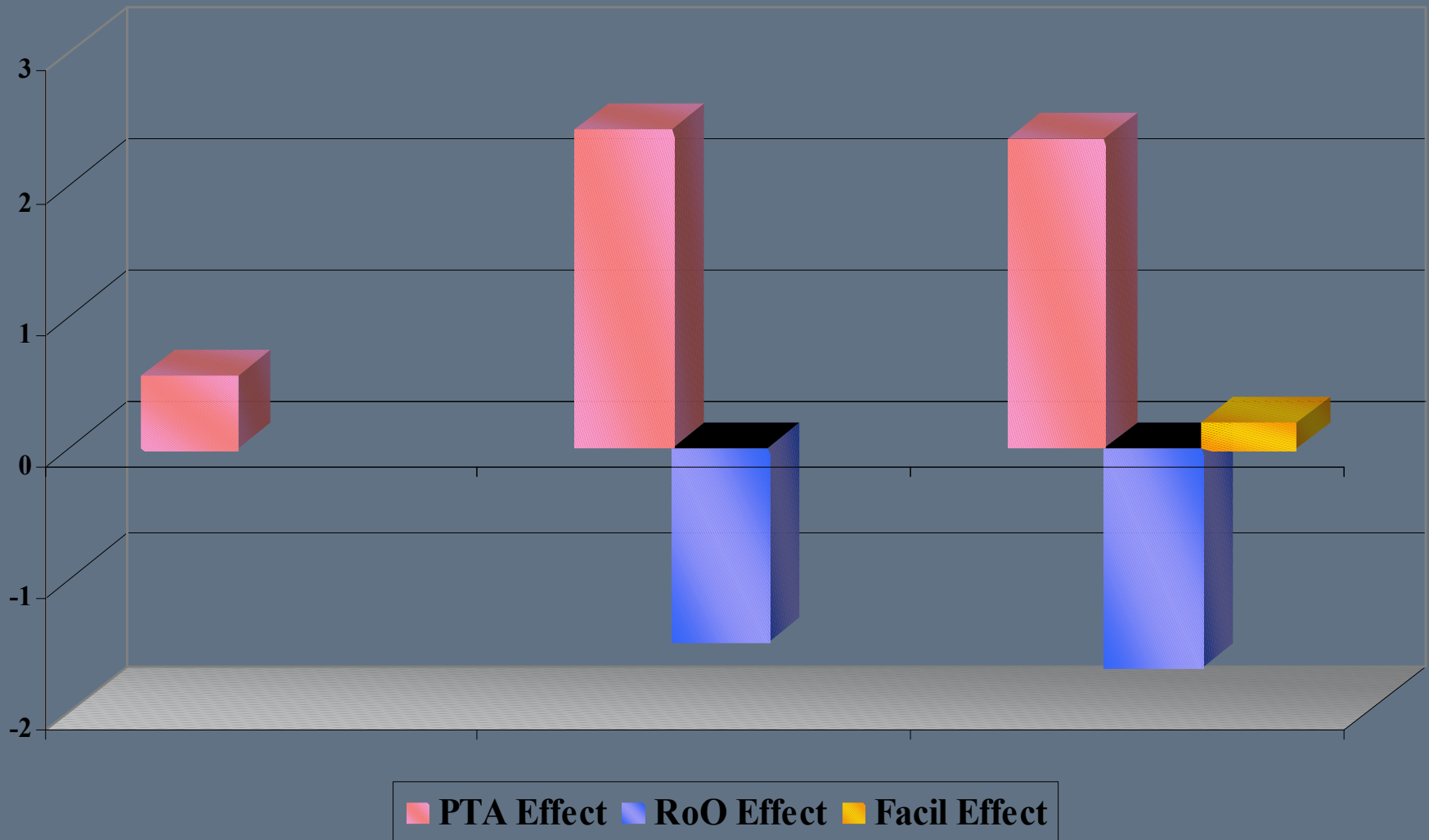

IV

Looking Beyond Economics: RTAs as Building Blocks for Cooperation

Trade (T) and Cooperation (C) Models

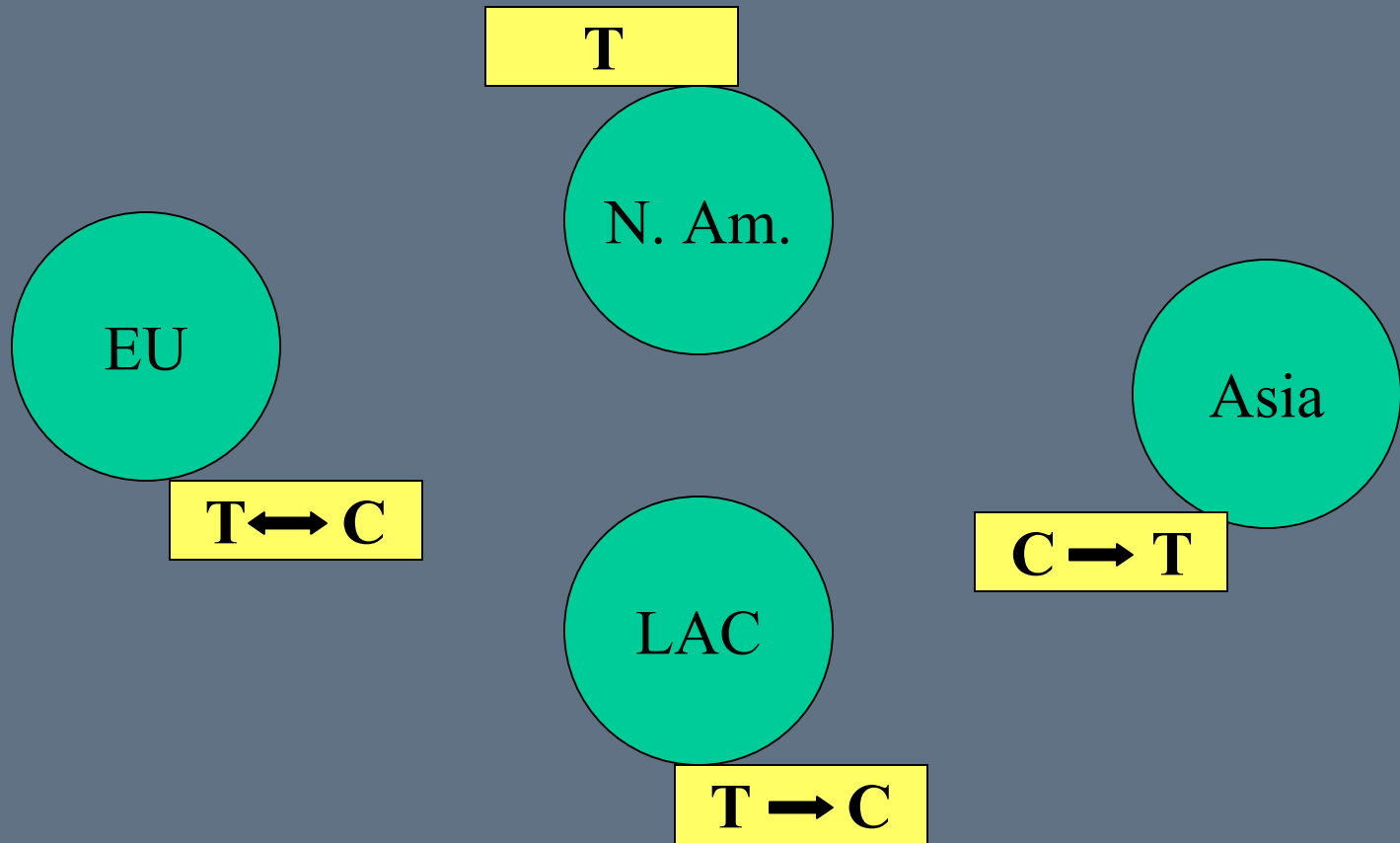

North-North & South-South Examples

Trade (T) and Cooperation (C) Models

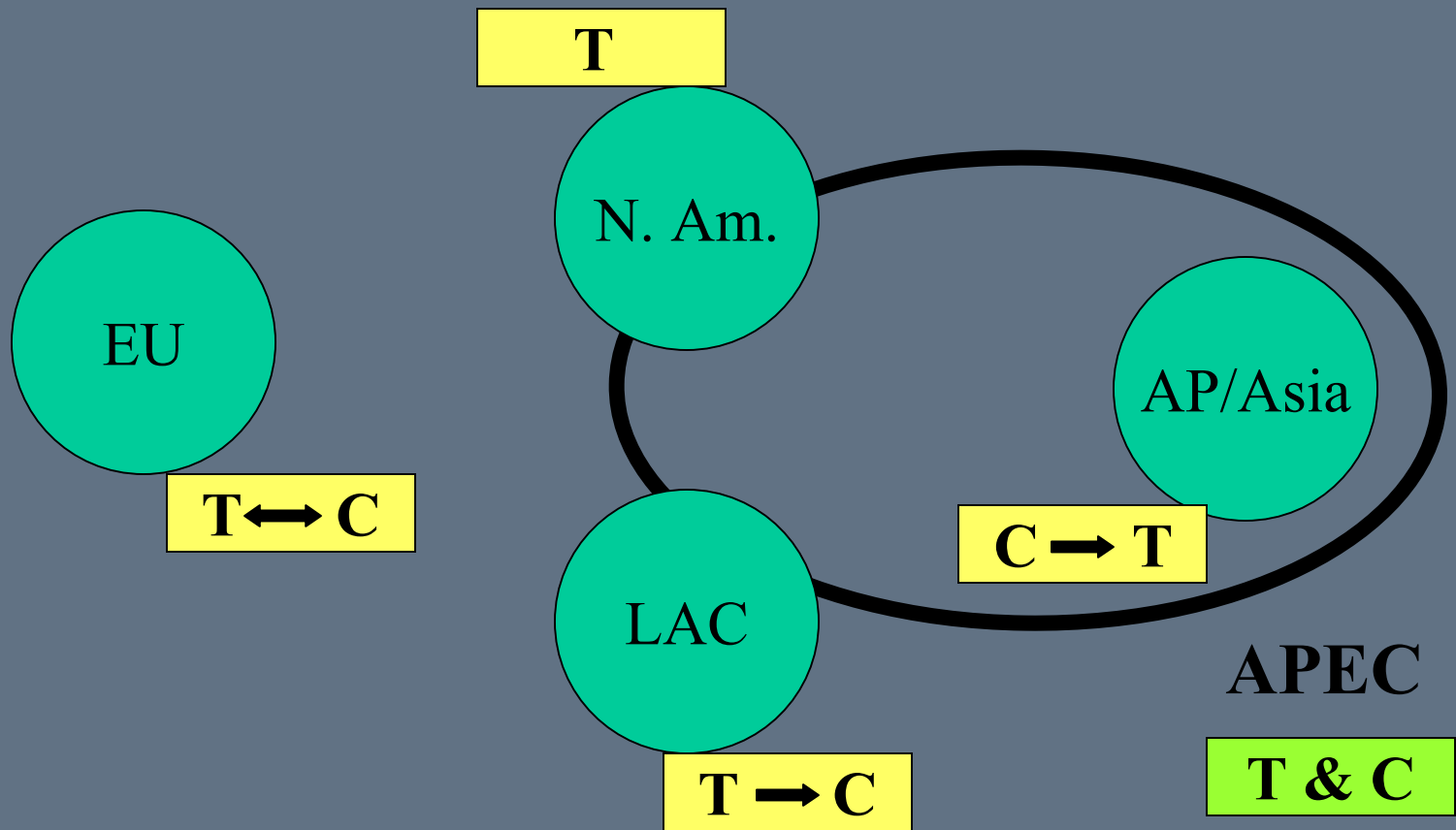

North-South Examples

Trade (T) and Cooperation (C) Models

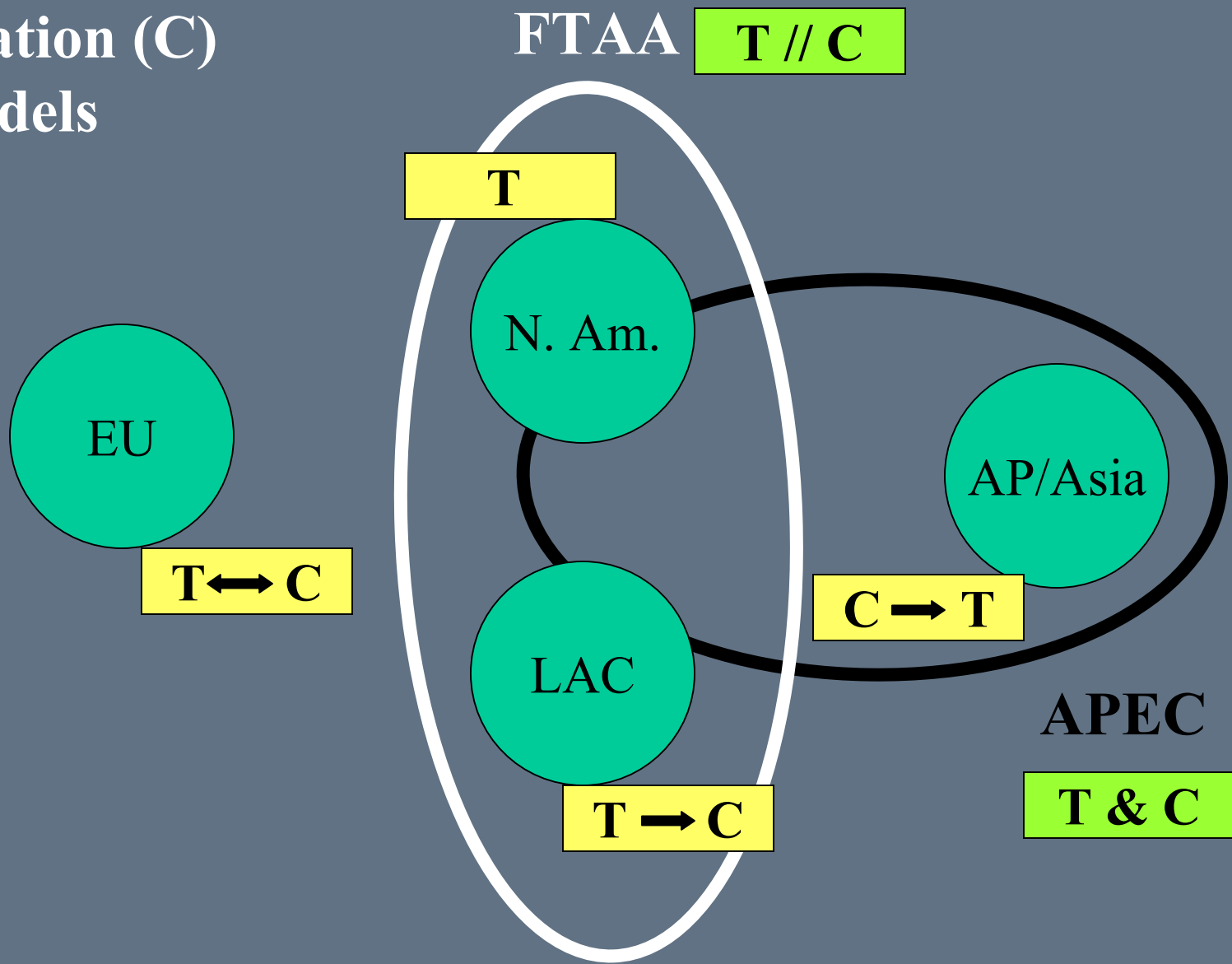

North-South Examples

Trade (T) and Cooperation (C) Models

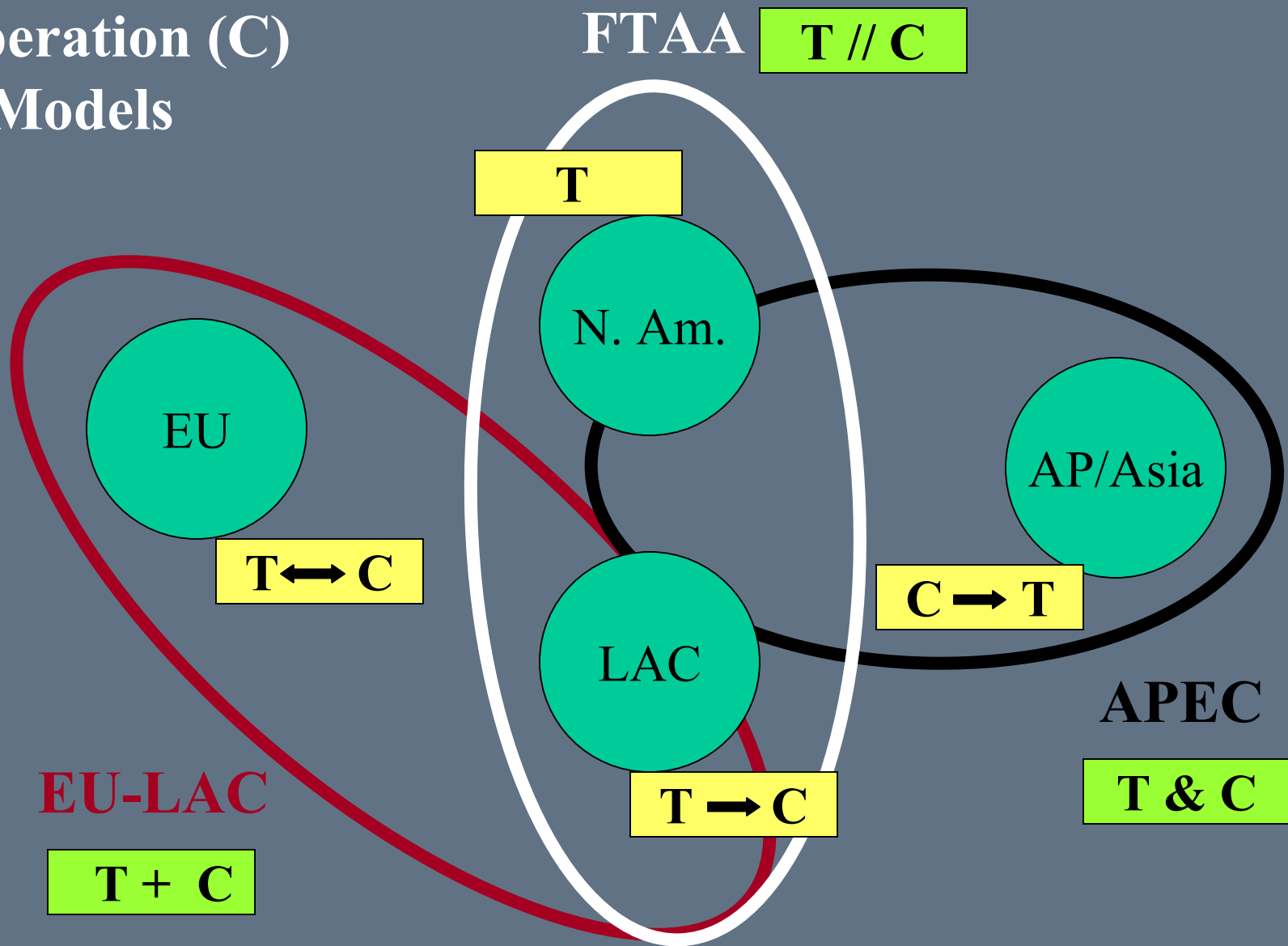

North-South Examples

Some Conclusions...

- Growing importance of interplay among RTAs (beyond traditional debate RTAs vs. WTO)
- Importance of serious empirical analysis to analyze economic (and non-economic) impacts of RTAs
- Importance of interplay between “trade” and “cooperation” mechanisms

Third CEPII-IDB CONFERENCE

**THE NEW REGIONALISM: PROGRESS, SETBACKS
AND CHALLENGES**

Washington, DC, February 2006

The Rise of Regionalism

Antoni Estevadeordal

**Integration and Regional Programs Department
Inter-American Development Bank**